

TRACK

EVENT INFORMATION	
DRIVER	ABEL LONGORIA
DATE	APRIL 26, 2003
EVENT	THRC FUNDRAISER 10
TRACK	TEXAS SPEEDWAY
LOCATION	HOUSTON, TEXAS
MISC	

LAP INFORMATION	
FASTEST LAP	21.8
QUALIFYING	DNF
	12 5:15.56
	13 5:10.84
MAIN	34 14:54.75
TQ TIME	13 5:00.21

TRACK CONDITIONS	
SURFACE	LOOSE & LOAMY
TEMP	85°
WEATHER	CLEAR & SUNNY
WATER	EVERY ROUND
MISC	QUALIFIED 4TH FINISHED 6TH

TRACK LAYOUT	
DIMENSIONS	124'-0" x 56'-0"

FRONT

SHOCKS	
SHAFT SIZE	3.0 (3.5)
PISTON	1.2ø x 2 1.3ø x 2
DRILLED	1.4ø x 2 1.6ø x 1
OIL	60 WT
SPRING	BLUE
PRELOAD	12 MM

SUSPENSION	
UPPER	A (B)
LOWER	A (B)
HUB CASTER	17° 20° 22°
TOE IN/OUT	-1°
CAMBER	-2°

SHOCK POSITION	
UPPER	
LOWER	INSIDE OUTSIDE
NOTES	

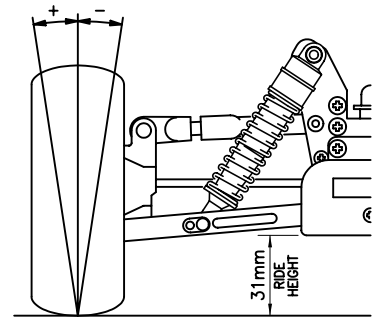

REAR

SHOCKS	
SHAFT SIZE	3.0 (3.5)
PISTON	1.2ø x 2 1.3ø x 2
DRILLED	1.4ø x 2 1.6ø x 1
OIL	40 WT
SPRING	BLUE
PRELOAD	7 MM

SUSPENSION	
PLATE	1" (2" 3")
HOLDER	1" 2" (3")
WHEELBASE	F 5 MM R 0 MM
HUB MOUNT	UPPER LOWER
CAMBER	-2°

SHOCK POSITION	
UPPER	
LOWER	INSIDE OUTSIDE
CAMBER LINKAGE	

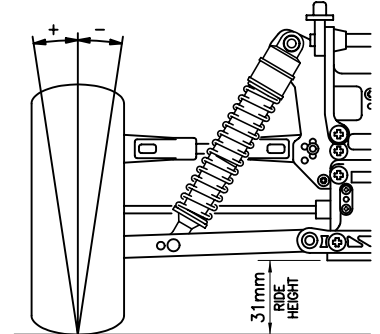

DRIVE TRAIN

ENGINE	
ENGINE	OS V01B
PLUG	OS A5
FUEL	RKT SCIENCE
AVERAGE TEMP	230°
SPUR	48 T

CLUTCH	
MAKE	MUGEN
STYLE	2pc (3pc)
MATERIAL	COMPOSITE
SPRINGS	1.10 SILVER
CLUTCH BELL	13 T

EXHAUST	
MAKE	OS
MODEL	T-2050
STYLE	1pc 2pc
MATERIAL	POLISHED
ADAPTER	NONE

DIFFERENTIAL SETUPS					
FRONT		CENTER		REAR	
(STD)	LSD	(STD)	LSD	(STD)	LSD
BLK	RED	BLK	RED	BLK	RED
5000 WT		7000 WT		1000 WT	
TORSEN		TORSEN		TORSEN	

DRIVE TRAIN

TIRES	
MAKE	GRP
MODEL	JOLLYS
COMPOUND	A - SOFT
FOAM	S (M) H
TRIMMED	PREMOUNTED

CLUTCH SHOE MODS	
2 SHOE	(3 SHOE)

SWAY BAR		
FRONT	2.3 ø	0 mm
REAR	2.8 ø	3 mm

STEERING		MISCELLANEOUS	
	BRAKE PADS	STOCK	
	BRAKE BIAS	F 30%	R 70%
	FUEL FILTER	1	(2)
WING	(UPPER LOWER)		

NOTES

FIRST RACE WITH THE BRAND NEW OS V01B, BROKE IT IN THE NIGHT BEFORE AND STILL RAN IT A BIT RICH TO BE ON THE SAFE SIDE. FINISHED EACH QUALIFIER WITH THE TANK BONE DRY. DNF'D THE FIRST QUALIFIER, FRONT LUNSFORD CAMBER LINK POPPED OUT, LINK WAS TOO SHORT FOR THE NEW K2 ARMS. CUT STOCK THREADED REAR LINKS AS A TEMPORARY FIX. THE DNF PUT ME IN 48TH AFTER THE FIRST ROUND, BUMPED UP TO 9TH AFTER THE SECOND ROUND, BUMPED UP TO 4TH AFTER THE THIRD ROUND. CHANGED THE GLOW PLUG BEFORE THE A MAIN AND THE CAR RAN VERY RICH, RAN OUT OF FUEL 10 FT FROM THE FINISH LINE. TRY RUNNING A SHORTER WHEELBASE, THAT MAY HELP IN THE TIGHT SECTIONS. BOTTOM NEEDED TO BE LEANED OUT IN THE A MAIN.