

## TRACK

EVENT INFORMATION	
DRIVER	YUICHI KANAI
DATE	NOVEMBER 29, 2002
EVENT	2002 WORLD CHAMPIONSHIPS
TRACK	
LOCATION	PUNTA DEL ESTE, URUGUAY
MISC	

LAP INFORMATION	
FASTEST LAP	
QUALIFYING	
MAIN	
TQ TIME	

TRACK CONDITIONS	
SURFACE	
TEMP	
WEATHER	
WATER	
MISC	

TRACK LAYOUT	
DIMENSIONS	

## FRONT

SHOCKS	
SHAFT SIZE	3.0 (3.5)
PISTON	1.2ø x 2 1.3ø x 2
DRILLED	1.4ø x 2 1.6ø x 1
OIL	500 WT
SPRING	BLUE
PRELOAD	12 MM

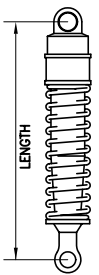

SUSPENSION		
UPPER	A	(B)
LOWER	A	(B)
HUB CASTER	17°	(20°) 22°
TOE IN/OUT	-1°	
CAMBER	0°	

SHOCK POSITION	
UPPER	
LOWER	(INSIDE) OUTSIDE
NOTES	

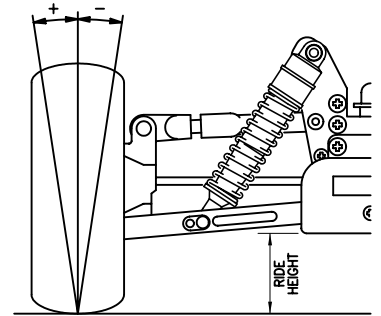

## REAR

SHOCKS	
SHAFT SIZE	3.0 (3.5)
PISTON	1.2ø x 2 1.3ø x 2
DRILLED	1.4ø x 2 1.6ø x 1
OIL	400 WT
SPRING	BLUE
PRELOAD	4 MM

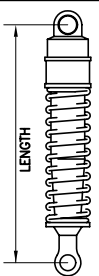

SUSPENSION		
PLATE	1°	(2°) 3°
HOLDER	1°	(2°) 3°
WHEELBASE	F 5 MM	R MM
HUB MOUNT	UPPER	LOWER
CAMBER	-0.5°	

SHOCK POSITION	
UPPER	
LOWER	(INSIDE) OUTSIDE
CAMBER LINKAGE	

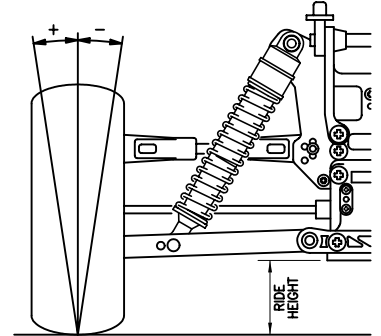

## DRIVE TRAIN

ENGINE	
ENGINE	RB WS7
PLUG	1056-6
FUEL	O'DONNELL
AVERAGE TEMP	
SPUR	46 T

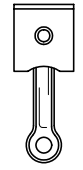

CLUTCH	
MAKE	
STYLE	2pc (3pc)
MATERIAL	
SPRINGS	1.10
CLUTCH BELL	14 T

EXHAUST	
MAKE	RB
MODEL	9863
STYLE	1pc 2pc
MATERIAL	POLISHED
ADAPTER	

DIFFERENTIAL SETUPS			
FRONT	CENTER	REAR	
STD (LSD)	STD (LSD)	(STD)	LSD
BLK (RED)	BLK (RED)	BLK	RED
WT	WT	1000 WT	
TORSEN	TORSEN	TORSEN	

## DRIVE TRAIN

TIRES	
MAKE	PRO-LINE
MODEL	CRIMEFIGHTER
COMPOUND	M2
FOAM	S M H
TRIMMED	EDGES



CLUTCH SHOE MODS	
2 SHOE	3 SHOE

SWAY BAR		
FRONT	2.5 ø	0.2 mm
REAR	2.8 ø	1.6 mm

STEERING	MISCELLANEOUS			
	BRAKE PADS			
	BRAKE BIAS	F	%	R %
	FUEL FILTER	1	2	
WING	UPPER LOWER			

## NOTES

\_\_\_\_\_  
 \_\_\_\_\_  
 \_\_\_\_\_  
 \_\_\_\_\_  
 \_\_\_\_\_